

СЕРИЯ '800'

1/2"-1 1/2"
В.Д.

СЕРИЯ '800'

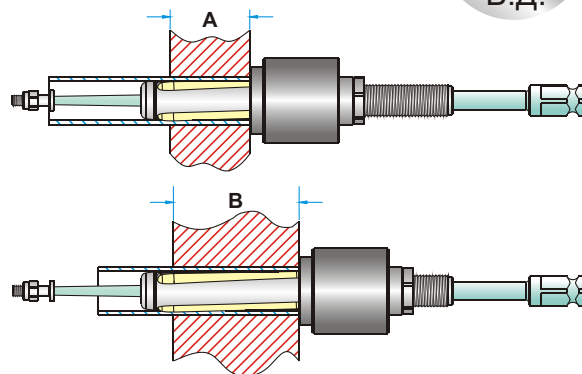

ДЛЯ ТРУБ С ВНУТРЕННИМ ДИАМЕТРОМ
от 8,4 мм до 36,3 мм

- Назначение: Вальцовки данной серии являются одними из самых востребованных в мире для обработки труб в теплообменниках и конденсаторах для труб с внешним диаметром от 8,4 мм до 36,3 мм.

ДЛИНА РОЛИКА ВАЛЬЦОВКИ	ТОЛЩИНА ТРУБНОЙ РЕШЕТКИ ДИАПАЗОН	
	МИНИМУМ А	МАКСИМУМ В
38.1мм (1.1/2")	12.7мм (1/2")	38.1мм (1.1/2")
57.1мм (2.1/4")	31.7мм (1.1/4")	57.1мм (2.1/4")

Внешний диаметр трубы, мм (дюймы)	Толщина стенки трубы			Внутренний диаметр трубы		Минимальный внутренний диаметр трубы для введения вальцовки		Максимальное Расширение		ВАЛЬЦОВКА с роликами длиной 38.10 мм (1.1/2")			ВАЛЬЦОВКА с роликами длиной 57.15 мм (2.1/4")		
	bwg	мм	inch	мм	inch	мм	inch	мм	inch	Код вальцовки	Веретено	Ролик	Код вальцовки	Веретено	Ролик
12.70 (1/2)	14	2.10	.083	8.4	.334	8.2	.324	9.5	.374	797	797	797	-	-	-
	15	1.82	.072	9.0	.356	8.8	.348	10.1	.398	799	799	R-1	-	-	-
	16	1.65	.065	9.4	.370	9.1	.360	10.4	.410	801	M-1	R-1	-	-	-
	17	1.47	.058	9.7	.384	9.5	.374	10.7	.424	803	M-1	R-2	-	-	-
	18	1.24	.049	10.2	.402	9.9	.392	11.3	.447	805	M-2	R-3	-	-	-
15.88 (5/8)	20	0.88	.035	10.9	.430	10.3	.406	11.7	.461	805 S	M-3	R-3	-	-	-
	12	2.76	.109	10.3	.407	9.9	.392	11.3	.447	805	M-2	R-3	-	-	-
	13	2.41	.095	11.0	.435	10.8	.425	12.1	.480	807	M-3	R-4	-	-	-
	14	2.10	.083	11.6	.459	11.4	.449	12.9	.509	809	M-4	R-4	810	M-4	R-4-A
	15	1.82	.072	12.2	.481	11.9	.471	13.6	.536	811	M-5	R-5	812	M-5	R-5-A
	16	1.65	.065	12.5	.495	12.3	.485	13.9	.550	813	M-5	R-6	814	M-5	R-6-A
	17	1.47	.058	12.9	.509	12.6	.499	14.3	.564	815	M-6	R-6	816	M-6	R-6-A
	18	1.24	.049	13.3	.527	13.1	.517	14.5	.572	817	M-7	R-7	818	M-7	R-7-A
	19	1.06	.042	13.7	.541	13.2	.522	14.7	.582	819	M-6	R-7	820	M-6	R-7-A
	20	0.88	.035	14.1	.555	13.6	.536	15.1	.596	819 S	M-8	R-7	820 S	M-8	R-7-A
19.05 (3/4)	21	0.81	.032	14.2	.561	13.6	.536	15.1	.596	819 S	M-8	R-7	820 S	M-8	R-7-A
	22	0.71	.028	14.4	.569	13.6	.536	15.1	.596	819 S	M-8	R-7	820 S	M-8	R-7-A
	10	3.40	.134	12.2	.482	11.9	.471	13.6	.536	811	M-5	R-5	812	M-5	R-5-A
	11	3.04	.120	12.9	.510	12.6	.499	14.3	.564	815	M-6	R-6	816	M-6	R-6-A
	12	2.76	.109	13.5	.532	13.2	.522	14.7	.582	819	M-6	R-7	820	M-6	R-7-A
	13	2.41	.095	14.2	.560	13.9	.550	15.6	.615	821	M-8	R-8	822	M-8	R-8-A
	14	2.10	.083	14.8	.584	14.5	.574	16.2	.639	823	M-8	R-9	824	M-8	R-9-A
	15	1.82	.072	15.3	.606	15.1	.596	16.7	.661	825	M-8	R-10	826	M-8	R-10-A
	16	1.65	.065	15.7	.620	15.3	.605	17.4	.685	827	M-9	R-10	828	M-9	R-10-A
	17	1.47	.058	16.1	.634	15.7	.619	17.7	.699	829	M-9	R-11	830	M-9	R-11-A
	18	1.24	.049	16.5	.652	15.7	.619	17.7	.699	829	M-9	R-11	830	M-9	R-11-A
	19	1.06	.042	16.9	.666	16.3	.642	18.3	.722	831	M-9	R-12	832	M-9	R-12-A
22.22 (7/8)	20	0.88	.035	17.2	.680	16.3	.642	18.3	.722	831	M-9	R-12	832	M-9	R-12-A
	21	0.81	.032	17.4	.686	16.3	.642	18.3	.722	831	M-9	R-12	832	M-9	R-12-A
	22	0.71	.028	17.6	.694	16.3	.642	18.3	.722	831	M-9	R-12	832	M-9	R-12-A
	10	3.40	.134	15.4	.607	15.1	.596	16.7	.661	825	M-8	R-10	826	M-8	R-10-A
	11	3.04	.120	16.1	.635	15.7	.619	17.7	.699	829	M-9	R-11	830	M-9	R-11-A
	12	2.76	.109	16.6	.657	16.3	.642	18.3	.722	831	M-9	R-12	832	M-9	R-12-A
	13	2.41	.095	17.4	.685	17.0	.670	19.0	.750	833	M-10	R-13	834	M-10	R-13-A
	14	2.10	.083	18.0	.709	17.4	.685	19.6	.774	835	M-11	R-14	836	M-11	R-14-A
	15	1.82	.072	18.5	.731	18.0	.712	20.3	.801	837	M-11	R-15	838	M-11	R-15-A
16	1.65	.065	18.9	.745	18.4	.726	20.7	.815	839	M-12	R-15	840	M-12	R-15-A	
17	1.47	.058	19.2	.759	18.8	.740	21.0	.829	843	M-12	R-16	844	M-12	R-16-A	
18	1.24	.049	19.7	.777	18.8	.740	21.0	.829	843	M-12	R-16	844	M-12	R-16-A	

Вальцовки моделей 797-856 поставляются с хвостовиками 3/8". Вальцовки моделей 857-900 поставляются с хвостовиками 1/2".

www.powermaster.ru



СЕРИЯ '800'

Внешний диаметр трубы, мм (дюймы)	Толщина стенки трубы			Внутренний диаметр трубы		Минимальный внутренний диаметр трубы для введения вальцовки		Максимальное Расширение		ВАЛЬЦОВКА с роликами длиной 38.10 мм (1.1/2")			ВАЛЬЦОВКА с роликами длиной 57.15 мм (2.1/4")		
	bwg	мм	inch	мм	inch	мм	inch	мм	inch	Код вальцовки	Веретено	Ролик	Код вальцовки	Веретено	Ролик
25.40 (1)	8	4.19	.165	17.0	.670	16.6	.655	18.6	.735	841	M-9	R-13	842	M-9	R-13-A
	9	3.75	.148	17.8	.704	17.4	.685	19.6	.774	835	M-11	R-14	836	M-11	R-14-A
	10	3.40	.134	18.5	.732	18.0	.712	20.3	.801	837	M-11	R-15	838	M-11	R-15-A
	11	3.04	.120	19.3	.760	18.8	.740	21.0	.829	843	M-12	R-16	844	M-12	R-16-A
	12	2.76	.109	19.8	.782	19.3	.763	21.6	.852	845	M-12	R-17	846	M-12	R-17-A
	13	2.41	.095	20.5	.810	20.0	.791	22.3	.880	847	M-12	R-18	848	M-12	R-18-A
	14	2.10	.083	21.1	.834	20.5	.810	23.0	.909	849	M-13	R-18	850	M-13	R-18-A
	15	1.82	.072	21.7	.856	21.2	.837	23.7	.936	851	M-13	R-19	852	M-13	R-19-A
	16	1.65	.065	22.1	.870	21.2	.837	23.7	.936	851	M-13	R-19	852	M-13	R-19-A
	17	1.47	.058	22.4	.884	21.9	.865	24.4	.964	855	M-13	R-21	856	M-13	R-21-A
	18	1.24	.049	22.9	.902	21.9	.865	24.4	.964	855	M-13	R-21	856	M-13	R-21-A
19	1.06	.042	23.2	.916	21.9	.865	24.4	.964	855	M-13	R-21	856	M-13	R-21-A	
20	0.88	.035	23.6	.930	21.9	.865	24.4	.964	855	M-13	R-21	856	M-13	R-21-A	
28.58 (1.1/8)	8	4.19	.165	20.1	.795	19.7	.776	22.2	.875	853	M-13	R-20	854	M-13	R-20-A
	9	3.75	.148	21.0	.829	20.5	.810	23.0	.909	849	M-13	R-18	850	M-13	R-18-A
	10	3.40	.134	21.7	.857	21.2	.837	23.7	.936	851	M-13	R-19	852	M-13	R-19-A
	11	3.04	.120	22.4	.885	21.9	.865	24.4	.964	855	M-13	R-21	856	M-13	R-21-A
	12	2.76	.109	23.0	.907	22.4	.883	24.9	.982	857	M-14	R-21	858	M-14	R-21-A
	13	2.41	.095	23.7	.935	23.2	.916	25.7	1.015	859	M-14	R-22	860	M-14	R-22-A
	14	2.10	.083	24.3	.959	23.7	.935	26.5	1.044	861	M-15	R-23	862	M-15	R-23-A
	15	1.82	.072	24.9	.981	24.4	.962	27.2	1.071	863	M-15	R-24	864	M-15	R-24-A
	16	1.65	.065	25.2	.995	24.4	.962	27.2	1.071	863	M-15	R-24	864	M-15	R-24-A
17	1.47	.058	25.6	1.010	25.1	.990	27.9	1.009	867	M-16	R-26	868	M-16	R-26-A	
18	1.24	.049	26.0	1.027	25.1	.990	27.9	1.009	867	M-16	R-26	868	M-16	R-26-A	
31.75 (1.1/4)	8	4.19	.165	23.3	.920	22.8	.901	25.6	1.010	865	M-15	R-25	866	M-15	R-25-A
	9	3.75	.148	24.2	.954	23.7	.935	26.5	1.044	861	M-15	R-23	862	M-15	R-23-A
	10	3.40	.134	24.9	.982	24.4	.962	27.2	1.071	863	M-15	R-24	864	M-15	R-24-A
	11	3.04	.120	25.6	1.010	25.1	.990	27.9	1.099	867	M-16	R-26	868	M-16	R-26-A
	12	2.76	.109	26.2	1.032	25.7	1.013	28.5	1.122	869	M-16	R-27	870	M-16	R-27-A
	13	2.41	.095	26.9	1.060	26.4	1.039	29.2	1.150	871	M-17	R-28	872	M-17	R-28-A
	14	2.10	.083	27.5	1.084	26.9	1.060	29.6	1.169	873	M-17	R-29	874	M-17	R-29-A
	15	1.82	.072	28.0	1.106	27.6	1.087	30.3	1.196	875	M-17	R-30	876	M-17	R-30-A
	16	1.65	.065	28.4	1.120	27.6	1.087	30.3	1.196	875	M-17	R-30	876	M-17	R-30-A
17	1.47	.058	28.8	1.134	28.3	1.115	31.0	1.224	879	M-18	R-30	880	M-18	R-30-A	
18	1.24	.049	29.2	1.152	28.3	1.115	31.0	1.224	879	M-18	R-30	880	M-18	R-30-A	
34.92 (1.3/8)	8	4.19	.165	26.5	1.045	26.0	1.026	28.8	1.135	877	M-17	R-31	878	M-17	R-31-A
	9	3.75	.148	27.4	1.079	26.9	1.060	29.6	1.169	873	M-17	R-29	874	M-17	R-29-A
	10	3.40	.134	28.1	1.107	27.6	1.087	30.3	1.196	875	M-17	R-30	876	M-17	R-30-A
	11	3.04	.120	28.8	1.135	28.3	1.115	31.0	1.224	879	M-18	R-30	880	M-18	R-30-A
	12	2.76	.109	29.3	1.157	28.7	1.133	31.5	1.242	881	M-18	R-32	882	M-18	R-32-A
	13	2.41	.095	30.1	1.185	29.4	1.160	32.3	1.275	883	M-19	R-33	884	M-19	R-33-A
	14	2.10	.083	30.7	1.209	29.9	1.179	32.8	1.294	885	M-20	R-34	886	M-20	R-34-A
	15	1.82	.072	31.2	1.231	30.6	1.206	33.5	1.321	887	M-20	R-35	888	M-20	R-35-A
16	1.65	.065	31.6	1.245	30.6	1.206	33.5	1.321	887	M-20	R-35	888	M-20	R-35-A	
38.10 (1.1/2)	8	4.19	.165	29.7	1.170	29.0	1.145	32.0	1.260	889	M-19	R-34	890	M-19	R-34-A
	9	3.75	.148	30.5	1.204	29.9	1.177	32.8	1.294	885	M-20	R-34	886	M-20	R-34-A
	10	3.40	.134	31.2	1.232	30.6	1.206	33.5	1.321	887	M-20	R-35	888	M-20	R-35-A
	11	3.04	.120	32.0	1.260	31.3	1.235	34.2	1.350	891	M-20	R-36	892	M-20	R-36-A
	12	2.76	.109	32.5	1.282	31.9	1.257	34.8	1.372	893	M-20	R-37	894	M-20	R-37-A
	13	2.41	.095	33.2	1.310	32.6	1.285	35.5	1.400	895	M-21	R-37	896	M-21	R-37-A
	14	2.10	.083	33.8	1.334	32.6	1.285	35.5	1.400	895	M-21	R-37	896	M-21	R-37-A
	15	1.82	.072	34.4	1.356	33.8	1.331	36.7	1.446	897	M-21	R-38	898	M-21	R-38-A
	16	1.65	.065	34.8	1.370	33.8	1.331	36.7	1.446	897	M-21	R-38	898	M-21	R-38-A
	17	1.47	.058	35.1	1.384	33.8	1.331	37.3	1.472	899	M-22	R-38	900	M-22	R-38-A
	18	1.24	.049	35.6	1.402	33.8	1.331	37.3	1.472	899	M-22	R-38	900	M-22	R-38-A
19	1.06	.042	35.9	1.416	33.8	1.331	37.3	1.472	899	M-22	R-38	900	M-22	R-38-A	
20	0.88	.035	36.3	1.430	33.8	1.331	37.3	1.472	899	M-22	R-38	900	M-22	R-38-A	

Вальцовки моделей 797-856 поставляются с хвостовиками 3/8". Вальцовки моделей 857-900 поставляются с хвостовиками 1/2".